

Description	Filter made of plastic for compressed air, vacuum, non-corrosive gases or liquids. The flow on the filter elements passes from outside to inside. They are largely corrosion-resistant and feature excellent chemical stability. Exposure of the filters to direct sunlight must be avoided. Optionally available with EPDM elastomers approved by the FDA.		
Filter element	5 µm, 35 µm and 80 µm made of PE, 50 µm, 100 µm and 300 µm made of stainless steel		
Bowl	made of transparent Grilamid TR55, three different sizes, screwable, without drain		
Drainage	without drain, as no water separation occurs with compressed air		
Operating pressure	max. 10 bar at 24 °C / 75 °F	Differential pressure	max. 0.7 bar
Temperature range	5 °C to 52 °C / 41 °F to 125 °F		
Cleaning	with lukewarm water and standard rinsing agent		
Material	Body: polypropylene GFV 20% Bowl: Grilamid TR55, transparent	Filter element: polyethylene, optionally stainless steel Elastomer: NBR/Buna-N, optionally FKM or EPDM (FDA)	

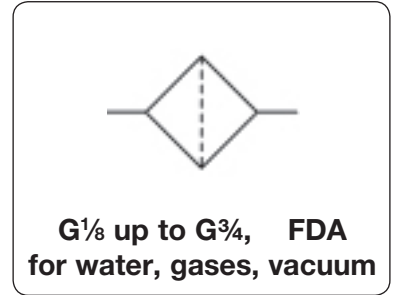

Dimensions			Bowl capacity l	Flow rate		Filter element µm	Connection thread G	Order number
A	B	C		water l/min*1	air l/min*1			
mm	mm	mm						

Plastic filter			operating pressure max. 10 bar differential pressure max. 0.7 bar	NBR/Buna-N o-ring polyamide, polypropylene		FH		
58	93	83	0.06	6	140	5	G ¹ / ₈	FH1-01G FH1-01J FH1-01L
					180	35		
					200	80		
74	95	85	0.06	8	180	5	G ¹ / ₄	FH1-02G FH1-02J FH1-02L
					230	35		
					300	80		
74	99	87	0.06	10	220	5	G ³ / ₈	FH1-03G FH1-03J FH1-03L
					280	35		
					300	80		
75	103	89	0.06	12	260	5	G ¹ / ₂	FH1-04G FH1-04J FH1-04L
					330	35		
					350	80		
90	124	112	0.17	14	400	5	G ³ / ₈	FH2-03G FH2-03J FH2-03L
					500	35		
					520	80		
90	128	113	0.17	16	480	5	G ¹ / ₂	FH2-04G FH2-04J FH2-04L
					600	35		
					620	80		
90	133	116	0.17	18	560	5	G ³ / ₄	FH2-06G FH2-06J FH2-06L
					700	35		
					720	80		



Special options, add the appropriate letter

with short bowl *2	shorter filter element, 4 l/min water	FH1 only	FH0-...
SST filter element	metallic tissue 50 µm S ; 100 µm T ; 300 µm		FH0-...U FH1-...U FH2-...U FH-...E FH-...V
EPDM elastomer	FDA-approved		
FKM elastomer			

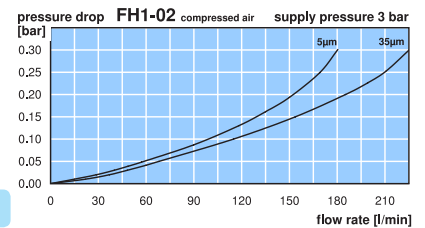

Accessories, enclosed

mounting bracket made of plastic for FH0 and FH1 for FH2 **BW17-01** **BW17-02**

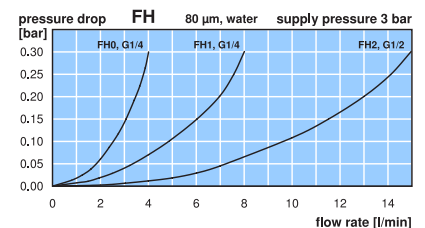
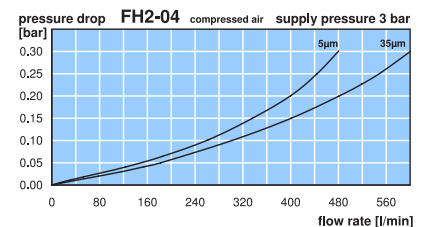
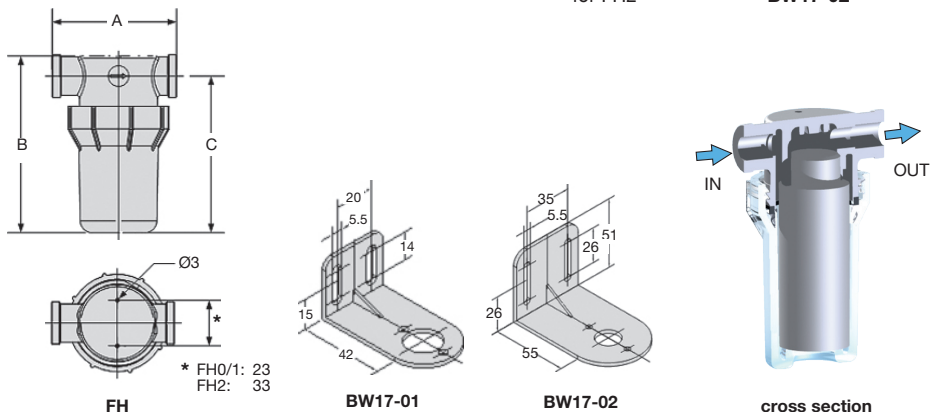

*1 at 3 bar operating pressure and 0.3 bar pressure drop
*2 flow reduced by 35%, height shortened by 35 mm, bowl capacity 0.014 l